



# DP450

## Tap Water Iontophoresis (TWI) System User Manual



(Included and optional accessories not shown)

# Table of Contents

<b>Table of Contents</b>	<b>2</b>
<b>Read Before Use</b>	<b>3</b>
Your Safety is Important	3
Contraindications	4
Side Effects	4
Additional Important Safety Considerations	4
<b>Intended Use / Mechanism of Action</b>	<b>5</b>
Treatment Fundamentals	6
Polarity Reversal and the Efficacy of Treatments	6
Types of Current	7
<b>System Components</b>	<b>8</b>
Standard Accessories	9
Optional Accessories	8
Control Unit Side & Rear Panel Elements	9
Control Unit Front Panel Elements	10
<b>Installation / Treatment Setup</b>	<b>11</b>
Setup for Hands and Feet Treatment	11
Setup for Axillary (Armpits) Treatment	12
<b>Conducting Treatments</b>	<b>12</b>
Primary Parameter Setup (Setup Mode)	13
Begin Treatment (Programming Mode)	15
Important Advice for Conducting Treatments	17
<b>Care and Maintenance</b>	<b>18</b>
Special Remark	18
Multi-Patient Use	18
Care and Purification	19
Disinfection	20
Reconditioning	21
<b>Troubleshooting</b>	<b>21</b>
Error Checklist	21
Operational Check	21
Shipping the Device for Repair or Maintenance	22
<b>Applicable Regulations and Legal Requirements</b>	<b>22</b>
Symbol Legend / Manufacturer / Device Identification	23
Lifespan	23
Electromagnetic Compatibility	24
Waste Management and Packaging of Electronic Devices	26
<b>Technical Data</b>	<b>26</b>
<b>Distribution/Trading</b>	<b>28</b>

## Read Before Use

Your HIDREX tap water iontophoresis device was designed to maximize functionality and usability. System setup is easy, and the device is simple to operate. This manual is intended to guide you through setup and programming, familiarize you with the system's features, and offer hints on the use of your new therapy system.



### Your Safety is Important

- ① This treatment system may only be powered by the HIDREX AC power adapter (which can be identified by a HIDREX nameplate with Serial-No.). This power supply is especially designed for this device.
- ① In order to prevent burns during treatment, make sure the supplied towels or pads cover the treatment electrodes at all times. Avoid direct contact with the metallic surface.
- ① Two devices may not be simultaneously used by one patient.
- ① Prior to treatment, remove any metallic jewelry (wedding bands, etc.) which would otherwise come in contact with the water source (trays or pads). Keeping such accessories on would lead to localized minor (electrical) burns that are secondary to increased current densities.
- ① Avoid application of current in excess of that which can be safely and comfortably tolerated by the patient. Always treat carefully and observe patient reaction.  
(As a rule, avoid current intensity greater than 0.5-1.0 milliamperes per square inch of active electrode area.)
- ① The long term effects of chronic electrical stimulation have not been established.
- ① Keep this device out of the reach of children.
- ① Caution: U.S. Federal law restricts this device to sale by or on the order of a physician.
- ① **WARNING:** Potential systemic adverse effects may result from use of this device. Drugs or solutions delivered with this device have the potential to reach the blood stream and cause systemic effects. Carefully read all labeling of the drug or solution used with this device to understand all potential adverse effects and to ensure appropriate dosing information. If systemic manifestations occur, refer to the drug or solution labeling for appropriate action.

## Contraindications



The following conditions are considered contraindications for iontophoresis, so treatment should not be administered unless otherwise directed by your physician:

- ① Patient with a cardiac pacemaker;
- ① Patient with an ICD (implantable cardioverter/defibrillator);
- ① Pregnancy;
- ① Patient with a metal-containing intrauterine device (IUD);
- ① Metallic implants within the current path (arm or leg);
- ① Large skin defects/wounds that cannot be covered with petroleum jelly;
- ① Patients with impaired sensibility in their hands or feet (e.g. patients with polyneuropathies);
- ① Potentially malignant lesions, acute localized infections, skin eruptions, or swollen, broken, or inflamed areas;
- ① Any area where sensation is absent or impaired;
- ① Apply electrical current through or across the chest, brain, or sinuses;
- ① Patients with suspected or diagnosed heart problems or epilepsy.

## Side Effects

Possible side effects or results of using this device include:

- ① Mild dysesthesia (tingling or burning)
- ① Short-term skin irritation (reddening) after treatment
- ① Erythema (skin redness, transient vesicles or blisters)
- ① Skin irritation or burns at the areas of electrode contact have been reported with the use of electrical stimulators.



## Additional Important Safety Considerations

- ⊗ Place the device on a firm level surface.
- ⊗ Make sure that the device is at room temperature before you power it up.
- ⊗ You may remove the treatment area from the water source at any time, but it is advisable to lower the dose to zero before you do so. In rare cases, safe but uncomfortable electric shocks<sup>1</sup> may result if the dose is not reduced.
- ⊗ The system should not be operated in the vicinity of shortwave or microwave medical diathermy devices. A minimum distance of 2 meters should be kept at all times.

<sup>1</sup> These electric shocks are definitely uncomfortable, but harmless.

- ⊗ Prior to using AC wall power, check that your outlet meets the system's requirements of 110-230 V~ and 50-60 Hz.
- ⊗ Unplug the AC power adapter if a thunderstorm approaches or if you do not intend to use the system for an extended period of time.
- ⊗ This device should only be used indoors. Do not expose the device to rain or excessive moisture.
- ⊗ Do not use kerosene, thinner, alcohol, wax remover or any other solvents.
- ⊗ Prior to cleaning the device, turn off the device and unplug all connectors. For cleaning, use a soft cloth moistened with a mild cleaning agent.
- ⊗ Prevent kinking of the cable and do not expose the cable to heat or chemicals. If the cable is damaged, unplug it from the device and have it checked by an authorized HIDREX repair center.
- ⊗ Never open the device; there are no control elements inside. The system may only be serviced by an authorized HIDREX repair center.
- ⊗ Wash the supplied towels on a regular basis together with your regular laundry (make sure to comply with the laundry instructions on the tag).

## Intended Use / Mechanism of Action

### Intended Use:

This tap water iontophoresis device is intended to treat hyperhidrosis<sup>1</sup> (excessive sweating) affecting hands, feet and underarms.

Any other use or usage beyond this scope is considered unintended use and may have dangerous consequences.



### Mechanism of Action:

During the HIDREX treatment, a current flows through the body regions that are being treated. The water in the trays or pads mediates this current flow. The skin areas in contact with the water will thereby secrete less sweat.

Although treatment success has been validated in numerous medical studies, there is still no completely satisfactory scientific explanation for the mechanism of action. Medical researchers believe that the electrical current irritates the synapses between sweat-inducing nerves and sweat glands to such an extent that sweat glands can no longer be stimulated. In other words: the treatment does not affect the sweat glands directly, it only affects the nervous input to these glands.

***This effect explains why the original condition returns relatively quickly when the treatment is discontinued.***

<sup>1</sup> Additional indications include: Dyshidrotic dermatitis, palmoplantar pustulosis and acrocynosis.

The treatment current can be adjusted according to your individual sensitivity. There is no risk involved as the current cannot exceed certain maximum values.

## Treatment Fundamentals

The HIDREX treatment concept comprises two treatment phases:

**Phase 1:** The initial phase (therapy initiation) is sometimes conducted under a doctor's supervision. During this stage, patients learn to administer treatments. For therapy initiation, at least three weekly treatments of approximately 15 minutes each should be scheduled (not more than one treatment per day). Sweat secretion will normalize after approximately 10 treatments.

**Phase 2:** Long-term treatment (maintenance therapy) is necessary because the HIDREX treatment effect is reversible. Depending on the severity of the condition, maintenance therapy involves one to three weekly sessions of approximately 15 minutes each.

## Polarity Reversal and the Efficacy of Treatments

It has been clinically documented that the area being treated with the anode (the electrode that is attached to the red/positive cable) will produce slightly better results initially than the area being treated with the cathode (the electrode that is attached to the black/positive cable).

It is recommended to conduct all treatments in the initial treatment phase (Phase 1) without changing polarity until one side reaches an acceptable dryness level. Once normal or acceptable dryness has occurred in one side of the treatment area (for example, right hand), then it is advisable to reverse polarity and continue the initial phase without changing polarity up to normal or acceptable dryness has occurred in the other side of the treatment area (for example, left hand).

Once normal or acceptable dryness has occurred in both sides of the treatment area (for example, both hands), then it is advisable to reverse polarity for each treatment during the maintenance phase (Phase 2).

Polarity is reversed simply by changing which side of the treatment area is treated by the anode or cathode (the electrodes with the red or black cable, respectively).

For example, on the first treatment in the maintenance phase, if the right hand was treated with the anode and the left hand was treated with the cathode, then on the next treatment, the right hand would be treated with the cathode, and the left hand would be treated with the anode. This sequence would continue for every treatment.

**Remark:** Failure to do this does not cause any harm or side effects, rather results in only a slight loss of efficacy. Long-term treatment results do not depend on the direction of current flow.

Only in the beginning of the initial phase (Phase 1), the anode (red cable) is slightly more effective than the cathode (black cable).

**Hint:** It is recommended NOT to reverse polarity within any given treatment session.

## Types of Current

The DP450 has several options for the type of current used during treatment:

- DC: Direct Current (standard)
- PC: Pulsed Current

PC is recommended as an option for treatment of underarms, or treatments where the skin is more sensitive, or for the treatment of children.

### **Direct Current (DC):**

In DC, the current (voltage) is being transmitted 100% of the time.

DC is the standard current of the device, and is the most efficient method of tap water iontophoresis treatment available.

Due to user comfort preferences, this device gives the user the option to choose PC as an alternative.

### **Pulsed Current (PC):**

In PC, the current alternates its transmission between ON (the pulse) and OFF (the pause) for equal lengths of time. The pulse and the pause are the same duration<sup>1</sup> (equivalent to a pulse-width of 50).

PC can be practically imperceptible at certain voltages and allows a better comfort level, but is typically slightly less effective.

**Hint:** Once selected for the treatment session, the pulse-width will remain the same throughout the session. If the user desires to change the pulse-width for better comfort or more efficiency, then the treatment must be stopped. Power must be cycled on the device to return to Setup Mode to change the pulse-width.

---

<sup>1</sup> for example, 50 microseconds ON and then 50 microseconds OFF, and then the cycle repeats

## System Components

Your HIDREX therapy system is comprised of a control unit and the accessories explained in the following sections.

Fig.: DP450



## Standard Accessories



- A** Hard Shell Case
- B** 2 treatment electrodes (covered in the picture)
- C** 2 towels

**D** Cable Set

**E** AC Adapter

## Optional Accessories

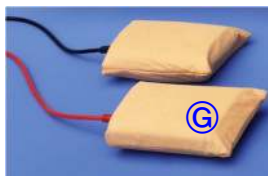

**F** Ergonomic treatment trays

**G** Axillary Treatment Kit<sup>1</sup>

<sup>1</sup> Axillary Treatment Kit includes a pair of small electrodes (AX electrodes) and a pair of pads (each pad consists of a sponge cushion with a leather cover)



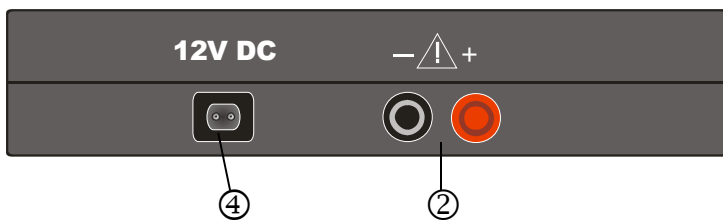
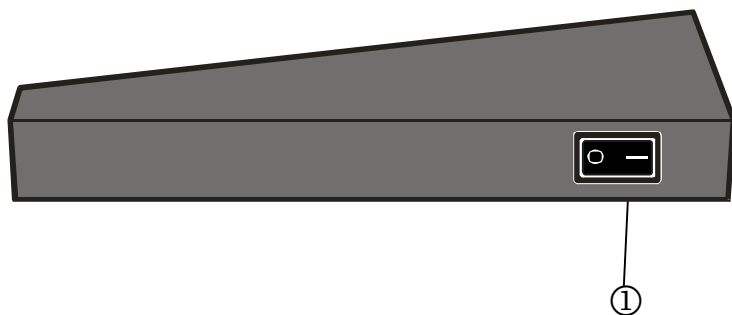

- ① Control unit main ON/OFF switch (main power switch)
- ② Jacks for connecting the cable set to the treatment electrodes
- ④ Connector for AC adapter (12V DC)

## Control Unit Front Panel Elements

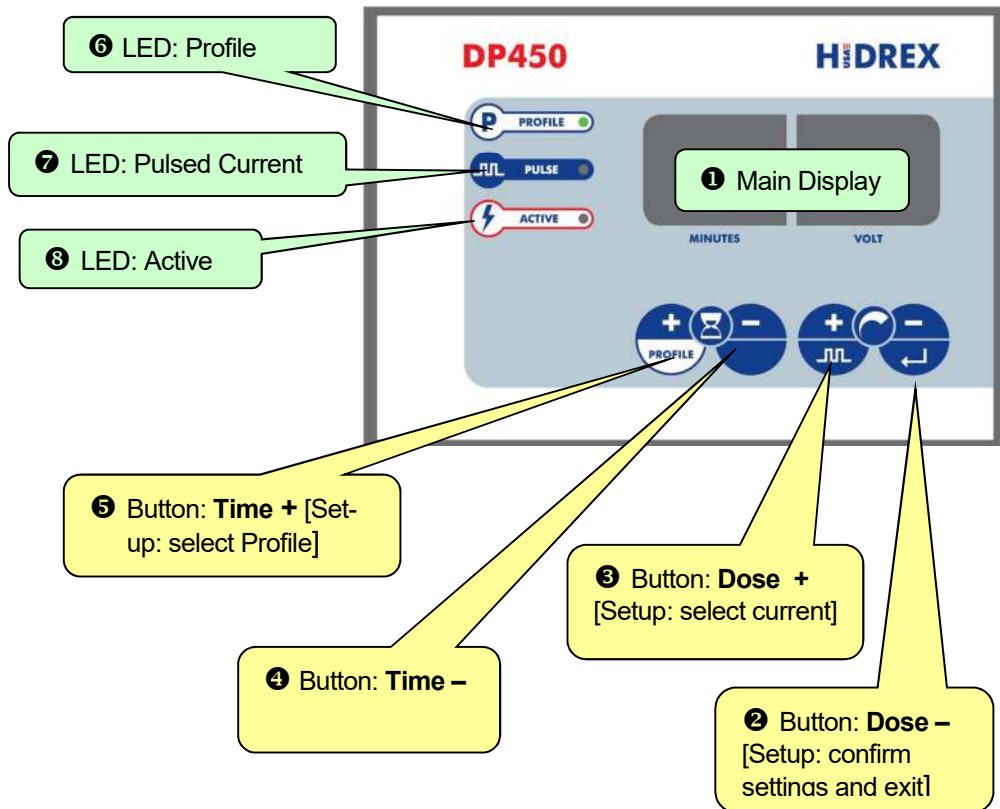

2	<b>Programming Mode: Lower dose</b> Setup Mode: Confirm settings and exit to then enter Programming Mode
3	<b>Programming Mode: Increase dose</b> Setup Mode : Select type of current (pulsed or direct)
4	<b>Programming Mode: Decrease time</b>
5	<b>Programming Mode: Increase time</b> Setup Mode (Select Profile)
6	Indicates <b>Profile (preset)</b> has been selected
7	Indicates <b>Pulsed Current</b> has been selected
8	<b>Active</b> – indicates that circuit is complete and device is active

## Installation / Treatment Setup

The following steps describe how you set up your therapy system for a treatment session. Please note that the setup for treating hands or feet is slightly different from the setup required for treating hands and feet simultaneously or for treating the underarms.

### Setup for Hands and Feet Treatment

- 1) Place the device on a firm, level surface. Make sure an electrical outlet is within reach.
- 2) Insert the AC adapter cable ⑤ into jack ④ on the rear panel and plug the adapter into an AC wall outlet.
- 3) Plug the color-coded connectors of the cable set ⑥ into the jacks ② on the back panel, to their matching colors.
- 4) Push the red and black terminals of the cable set ⑥ firmly onto the respective connectors on the treatment electrodes ⑦. **Make absolutely sure to forcefully push the connectors all the way onto the necks of the treatment electrodes.**
- 5) Place one treatment electrode ⑦ in each hard shell case<sup>1</sup> ⑧, or in each ergonomic treatment tray ⑨, respectively. When using the ergonomic treatment trays ⑨, make sure the sloping rims point toward you – this will facilitate hand immersion and increase comfort.
- 6) Completely cover the long part of each treatment electrode ⑦ with a towel ⑩.
- 7) Fill both hard shell cases or treatment trays with warm tap water so that the skin areas to be treated can be easily immersed. (It is recommended to fill the trays with just enough water to treat the skin areas requiring treatment so that you get the most efficient treatment possible. Filling any higher is unnecessary and may result in a slightly less efficient treatment.)

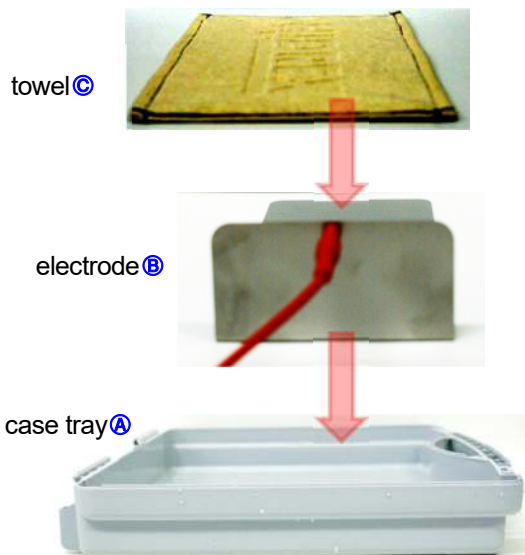

<sup>1</sup> The two basins of the case can easily be separated by pushing the left side away from you while pulling the right side toward you. The case must be completely open (lying flat) before attempting to separate the sides.

Remark: One or both of the aluminum electrodes may discolor after several treatments. This is completely normal, and will not affect the efficacy of the treatment.

## Setup for Axillary (Ampits) Treatment

The setup for axillary treatment is similar to the setup for hand or feet treatment, except that axillary treatment requires the Axillary Treatment Kit<sup>Ⓒ</sup> instead of trays.

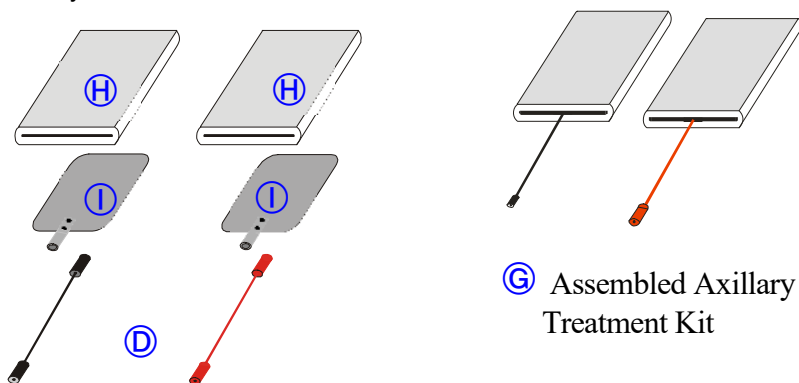

Proceed with steps 1 to 4 of the instructions on the previous page.

Thoroughly soak the axillary pads (sponges with leather covers)<sup>Ⓗ</sup> with hand warm tap water. At this time, insert the AX electrodes<sup>Ⓘ</sup>

**Hint: Do not squeeze any water from the pads!**

Subdivide every axillary treatment into two sessions of 7 minutes each, in order to re-soak the axillary pads.

## Conducting Treatments

**For your comfort, please observe the following two instructions before you begin a treatment session:**

- 1) BEFORE you start a treatment session and close the electrical current circuit with your hands, feet or underarms, make sure to FIRST turn ON the main power switch<sup>Ⓢ</sup>. If this sequence is reversed, there is also a chance that you receive a completely harmless, but uncomfortable, electric shock!
- 2) When conducting a treatment, avoid removing your hands or feet from the water or removing the Axillary Treatment Kit from your underarms. If you ignore this advice, you run a very small risk of feeling a completely harmless, but uncomfortable, electric shock. Although the HIDREX system comes equipped with a feature called Anti Shock Electronics (ASE<sup>Ⓒ</sup>) designed to permit current flow interruption, there is a very small chance of this shock occurring due to various other circumstances.

## Primary Parameter Setup (Setup Mode)

Before you initiate a treatment session, you can choose between various options depending on the area you want to treat. The following describes how to select and store these parameters:

- 1) After setting up your HIDREX therapy system in accordance with the instructions in the “Installation” chapter, turn on the control unit by pushing the main power switch ①.

First, the main display ❶ will briefly show three moving bars for about 5 seconds (self-test of the device).

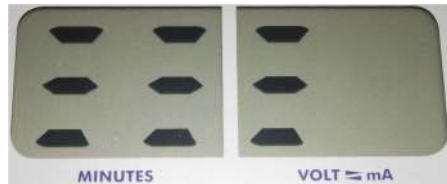

Next, the following text “SET” is shown and indicates the device is in Setup Mode.

The selected options are indicated by the LED ❷ and LED ❸ during Setup Mode and during treatment also.

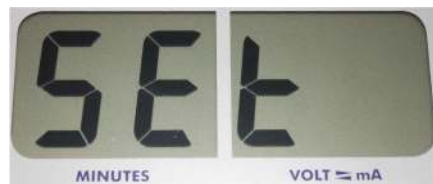



**Important:** If no button is pressed within 6 seconds, the device will automatically switch from Setup Mode to Programming Mode.



**Hint:** When the device automatically switches to Programming Mode, the settings that were used on the last treatment session (or factory presets if the device was never used before) will automatically be used.

For example, if the last treatment had a pulsed current, a dosage of 18 volts, and a duration of 10 minutes, then these settings would be stored and used again until changed.

- 2) While in Setup Mode, activate or deactivate the options as desired<sup>1</sup>:

Option	Function	Symbol
Button ❷ 	<u>Profile:</u> If PROFILE is active, the most recent “time” and “dose” settings will be saved; if inactive, the system is in manual mode and will return to factory preset when turned back on.	LED ❷ ON = active 

<sup>1</sup> Adjust the system in accordance with your doctor’s instructions.

<p>Button ③</p> 	<p><u>Pulse:</u> When PULSE is active, pulsed current is used instead of direct current.</p>	<p>LED ③ ON = pulsed current LED ③ OFF = direct current</p> 
<p>Button ②</p> 	<p><u>ENTER key</u> Is used to go directly into Programming Mode without waiting for 6 seconds.</p>	

**Important:** The Setup Mode is accessible only directly after switching on the device. If you leave the Setup Mode, you must turn off the device briefly and then turn it on again in order to access Setup Mode and alter the above treatment options.

**In the factory, your DP450 is pre-set as follows:**

Pulsed Current:	OFF
Time:	15 minutes
Dose:	4 Volts

Below are some recommendations for *initial* treatment, although most users increase the voltage as they get more comfortable with the device. Each user should experiment to see what works for them and how the treatment feels. It is recommended to increase the voltage as it can be tolerated.

Treatment area	Treatment parameter	
<b>HANDS</b>	Pulsed Current Time: Dose:	ON 15 minutes 20 Volts
<b>FEET</b>	Pulsed Current: Time: Dose:	OFF 15 minutes 30 Volts
<b>Axillary (underarms)</b>	Pulsed Current : Time: Dose:	ON 15 minutes 8 Volts



In order to avoid skin irritation by excessive dose settings in pulsed mode (where current flow is practically imperceptible), we recommend that you assess your individual direct current thresholds for hands, feet, or armpits before you start the first treatment session. To conduct axillary treatments, as a rule the dose should not be raised above 15 volts, because the sensitive skin may otherwise get burnt.

## Begin Treatment (Programming Mode)

After completion of the initial setup, the unit will automatically switch to Programming Mode after about 6 seconds or when the ENTER button **2** is pressed. The intended treatment time and dose will be displayed, based on Profile or manual mode. Before you start the actual treatment session, you need to check and/or set the “time” and “dose” treatment parameters.

### 1) Setting treatment parameters:

If Profile has been selected, the device uses the saved treatment parameters<sup>1</sup>. If the device is in manual mode, it will return to factory presets when turned back on.

The numbers in the left window show the selected treatment duration in minutes and the numbers in the right window show the selected treatment dose in volts.

Select the desired treatment dose<sup>2</sup> with buttons **2** and **3**, and the desired treatment duration with buttons **4** and **5**.



Each time you push one of these buttons, the corresponding treatment parameter is increased or decreased by one minute or one volt, respectively.

**Hint:** By holding one of the push buttons down, you can continuously increase or decrease the corresponding treatment parameter.

<sup>1</sup> pulse-width, time and dose

<sup>2</sup> Select the dose in accordance with your doctor's orders or use the table of factory pre-set treatment parameters for guidance.

**Hint:** The system saves these settings if Profile is active even if you adjust parameters during a treatment. The device will automatically suggest these parameters<sup>1</sup> when a new treatment session is started.

## **2) Starting the Treatment:**

When treating hands or feet, place each hand or foot onto one towel<sup>Ⓒ</sup> each that are covering the electrodes in the carrying case trays<sup>Ⓐ</sup> or ergonomic treatment trays<sup>Ⓑ</sup> that are sufficiently filled with tap water according to the installation instructions noted previously. Make sure that your skin does not touch the electrodes directly.



**Do not forget to remove any jewelry!**

**Avoid direct contact between skin and the metal electrode!**

To conduct an axillary treatment, place the pre-soaked axillary pads<sup>Ⓒ</sup> into your underarms. Make sure the pads fit well and apply even pressure to maximize the contact area.



When the built-in “immersion monitoring” system recognizes that the circuit is closed, the ACTIVE LED <sup>Ⓒ</sup> lights up to indicate that the treatment is active.

When treatment is active (ACTIVE LED <sup>Ⓒ</sup> light is ON) the actual dose being currently administered is displayed on the right of the display. Upon immersion or start of a treatment, the dosage always starts at zero and then slowly increases to the desired dose previously set.



**Note:** The dose measurement can be in milliamps or volts, depending on your selection in the Setup Mode; it can also be toggled during an active treatment, but NOT during Programming Mode.

**Important:** If you experience any localized pain during a treatment, you need to interrupt the session and cover the painful area with petroleum jelly. Pressing any button will stop the automatic increase of the treatment dose.



## **3) Adjusting treatment parameters:**

At any time throughout the treatment session, you can change treatment time and dose settings by pressing the respective push buttons.

If you interrupt the treatment by removing the treatment area from the water source, the ACTIVE LED <sup>Ⓒ</sup> goes off and the treatment timer is paused. The



display shows the remaining treatment time and the selected dose in volts. When you continue the treatment, the ACTIVE LED ③ will light up again and the dose display changes to zero, before it slowly increases to the desired value.

#### **4) Ending a treatment session:**

When the treatment time is up, the treatment dose is automatically lowered to zero. Please keep your hands and feet in the trays (or the axillary pads in place, respectively) until the dose display reads “End”.

**Remove the treatment area from the water source (trays or pads) and THEN switch the device off.**

### **Important Advice for Conducting Treatments**

For your safety, your HIDREX treatment system comes equipped with several protective circuits.

#### **Immersion monitoring**

Immersion monitoring is a built-in feature that detects when the treatment electrical current circuit is closed due to immersion of the palms or feet, or placement of the pads under the arms. The ACTIVE LED ④ will light up when the circuit is closed and treatment is active.

#### **Over Treatment Protection (OTP) Feature**

If your skin is dryer than normal<sup>1</sup>, the dose cannot be increased (protection against over-treatment). Your HIDREX system automatically checks your specific skin conductance. If your skin conductance is beyond the preset threshold, the protection circuit is activated and locks the system. The ACTIVE LED ⑤ does not light up, even when the treatment current path is closed.

**Hint:** To double-check if over-treatment protection has been activated for you (and that it is not a fault of the device), you can run a quick operational check of the device to confirm that it is your skin conductance and not the device. Simply take one cable and insert each end into a jack on the module AFTER the device is in Programming Mode. This closes the circuit; the ACTIVE LED ⑤ will light up if the device is working properly.

If over-treatment protection is activated, you should interrupt your treatment course for at least one week until excessive perspiration returns.

Please contact us if the OTP feature has been activated **AND** you still have excessive perspiration, which is a situation that may arise in very rare circumstances.

---

<sup>1</sup> This does not relate to the surface skin layer, but to the moisture content of the deeper skin layers, an indicator of the extent of hyperhidrosis.

## **Current Limitation**

In cases of very heavy sweating (which indicates a low electric resistance of the skin and easier current flow), the maximum treatment current can be reached before the specified dose (volt value) is achieved. A protection circuit (current limitation) intervenes in this case and stops the device.

**This doesn't have any influence on the completion of the session and protects you only against burns!**

During the course of further treatments, higher dose values are gradually reached as perspiration decreases (the electric resistance of the skin increases so higher doses are necessary for effectiveness).

The protection circuit may *appear* to react faster when using pulsed current mode, but this is not the actual case. In PC or VPC mode, the "average" dose value is displayed, but the device monitors the maximum current, not the average<sup>1</sup>.

## **Safety circuit**

The DP450 has a safety circuit which stops the treatment in the case the current exceeds 30 mA. In this case, the display will show "StOP" and all LEDs will blink. Please turn it off, unplug the power supply from the wall and send the device with all electrical accessories back to us if this occurs. Please refer to section "Shipping the Device for Repair or Maintenance".

## **Care and Maintenance**

This section contains important instructions about your HIDREX system.

## **Special Remarks**

Our responsibility for system safety, functionality, and reliability applies only if any maintenance and servicing is exclusively performed by an authorized HIDREX repair center. Our warranty ceases and we assume no liability if any manipulation or service is performed by unauthorized personnel.

The regulations valid in the respective operator's country (e.g., infection prevention, technical servicing or registration and documentation regulations) are to be kept in connection with the location of use (e.g., medical institution), in any case, by the operator.

## **Multi-Patient Use**

The device is suitable for the use by several patients at the prescribing physician's office or hospital, to conduct the initial or maintenance phases of the treatment under a doctor's supervision.

---

<sup>1</sup> For example, if PC (50% pulse-width) is used, the displayed value has to be doubled to calculate the current limit.

As a communal device for multi-patient use, the following protocols should be obeyed:

- Each patient will be provided with **own** consumables for HIDREX iontophoresis treatment (pair of towels or axillary pads)<sup>1</sup>, which can be re-used to every session.
- Between treatments, the electrodes<sup>ⓑ</sup> and trays (hard case trays<sup>Ⓐ</sup> or ergonomic trays<sup>ⓕ</sup>) must always be cleaned, dried and disinfected finally, as described in the following section.

**Remark:** It is at the physician's discretion whether to issue (sell) either the actual device used during in-office treatments or a brand new device to any given patient.  
In either case, if the device issued (sold) is ever in need of repair or replacement parts or additional accessories are needed, the patient can contact customer service at 1-8HIDREXUSA (1-844-373-9872) or [customer.service@hidrexusa.com](mailto:customer.service@hidrexusa.com).

## Care and Purification

For flawless and long-lasting function of your HIDREX tap water iontophoresis device, we recommend the following steps after each use:

### Care after each treatment:

Wash out towels<sup>Ⓒ</sup> or axillary pads<sup>ⓗ</sup> thoroughly with clean water (without addition of detergents or cleaning agents).

- Squeeze dry the towels<sup>Ⓒ</sup> or axillary pads<sup>ⓗ</sup> rigorously to remove excess moisture.
- Let the towels<sup>Ⓒ</sup> or axillary pads<sup>ⓗ</sup> air-dry (do not store in the closed hardcase due to humidity!)
- Dry the electrodes<sup>ⓑ</sup> with a soft cloth, to prevent calcium deposits on the sheet metal. Please make sure to remove any moisture from the treatment electrodes after each treatment!
- Dry the treatment trays (hard case trays<sup>Ⓐ</sup> or ergonomic trays<sup>ⓕ</sup>) with a soft cloth and let them air-dry (do not close the hard case tray due to humidity!)

### Purification / Cleaning (every 5 sessions or whenever necessary)

**Warning:** Before cleaning, make sure the device is turned off and separated from the power line. Never use kerosene, thinner, or other solvents.



- The control unit, the treatment trays (hard case trays<sup>Ⓐ</sup> or ergonomic trays<sup>ⓕ</sup>) and electrodes<sup>ⓑ</sup> should be cleaned with a moistened cloth or with a common detergent.

<sup>1</sup> It is suggested that the consumables are given to the patient to take home and clean themselves and then bring them back to subsequent sessions.

- Hand wash the axillary pads **Ⓟ** with 140° - 195°F (60° - 90°C) water and common detergent. Rinse thoroughly with clean water, squeeze dry rigorously and let the pads air-dry.
- Hand or machine wash the towels with 140°F (60°C) water and a common detergent. Dry the towels by dryer or air-dry.

**Important:** Calcifications on the electrodes can hinder the treatment current. This deposit can be removed with a common descaler, or even vinegar or citric acid.

A discoloration of the electrode metal after the first treatment sessions is normal.

### **Maintenance:**

HIDREX tap water iontophoresis devices are basically maintenance-free.

Nevertheless, for safety reasons we recommend a technical check and safety inspection by an authorized HIDREX repair every 2 years.

Suitable measuring and test equipment is mandatory for the technical safety inspections which cover at least the following:

- Visual check of medical device and accessories
- Protective conductor test in accordance with EN 60601-1:2007
- Leakage current test in accordance with EN 60601-1:2007
- Operational check of the medical device.

### **Disinfection**

Because exclusively unscathed skin will be treated, the HIDREX tap water iontophoresis devices are classified as “non-critical”<sup>1</sup> concerning disinfection.

As a communal device for multi-patient use, the following protocol should be obeyed:

- Spray a surface disinfectant<sup>2</sup> on the electrodes **Ⓟ** and treatment trays (hard case trays **Ⓐ** or ergonomic trays **Ⓢ**) so that the entire surfaces are completely moistened.
- Let the disinfectant remain on the surface as directed by its instructions and then wipe it dry with a clean cloth.
- The consumables should be replaced by new or patient owned towels **Ⓢ** or axillary pads **Ⓟ**.

<sup>1</sup> For single-patient use in home therapy, the care and purification according to the preceding chapter is sufficient. In this case a regular disinfection is not strictly necessary.

<sup>2</sup> Henkel: Incidin Extra (1%), Incidin Plus (0.5%), Minutil (0.5%)

Dr. Trippen (desomed): Biguamed

Bbraun: Melesept SF (0.5%/5%), Hexaquart S (1.5%/5%), Meliseptol (undeluted)

## Reconditioning

HIDREX tap water iontophoresis devices are reusable medical devices and can be reconditioned after use of a customer. The reconditioning of the devices is classified as “non-critical”.

The reconditioning should be done only by an authorized HIDREX repair center. If a device is to be reconditioned, the following actions will also be taken:

- The consumables (towels © or axillary pads Ⓜ) need to be disposed of and replaced by new ones.
- The accessories, treatment trays (hard case trays Ⓐ or ergonomic trays Ⓜ) and electrodes Ⓜ need to be disposed of and replaced by new ones.
- The control unit must be purified and disinfected.
- A technical check and safety inspection must be completed and documented.

The medical device may be reconditioned up to 10 times.

## Troubleshooting

If prior to, during, or after a treatment session, the device does not operate in accordance with this manual, please go through the following checklist and perform the operational check before you send the device for repair. This can save you considerable cost and inconvenience. Thank you!

### Error Checklist

Please go through this checklist as the first step in troubleshooting:

- ⊗ Verify that the AC power adapter is properly connected to the control unit and to the wall outlet.
- ⊗ Verify that the connectors on the cable set are pushed far enough onto the receptacles of the treatment electrodes for establishing a reliable connection.
- ⊗ Verify that the device works properly on another person. If it does, over-treatment protection is on and you will need to wait until your skin needs treatment before using again.

**Hint:** In rare cases, tap water conductance may be inadequate (e.g. when tap water deionizing equipment is in use). In that case, try non-carbonated mineral or table water instead to raise the current.

### Operational Check

Proceed with the following steps for an operational check of your system:

- 1) Set up the therapy system as you would for a treatment.
- 2) Activate the main power switch ① to turn the control unit ON. Dose and treatment time settings should appear on the main display ②.

- 3) Take one cable (red OR black) and insert each end into a jack on the module AFTER the device is in Programming Mode. This closes the circuit;
- 4) The ACTIVE LED ⑨ will light up if the device is working properly.

If the ACTIVE LED ⑨ does not light under this test although the items on the error checklist have been followed, please contact us or our distributor to coordinate the required steps.

## Shipping the Device for Repair or Maintenance

The device should only be shipped in the supplied carrying case. If possible, use the original packaging material for shipping. Make sure the device is protected against impact inside the case and that packaging is suitable for shipping.

***Prior to shipping, do not forget to clean and dry the system and the accessories. Please do not ship towels, axillary pads or any other pads.***









Please send all electrical accessories (AC power adapter ⑥, electrodes ⑧, AX electrodes ① and cable set ②) together with the HIDREX control unit.

## Applicable Regulations and Legal Requirements

The regulations valid in the respective operator's country (e.g., infection prevention, technical servicing or registration and documentation regulations) are to be kept in connection with the location of use (e.g., medical institution), in any case, by the operator.

**Hint:** Individuals who only use the device privately usually do not have to comply with special requirements.

## Symbol Legend / Manufacturer / Device Identification

	Caution, Power Output	Connector for electrodes + = Anode , - = Cathode
	Shock Protection Type	Device leakage currents comply with stand-ards -- the system provides protection against electrical shock (Type B); device is insulated (floating) (Type F).
	Prescription Use Only	Federal law restricts this device to sale by or on the order of a physician.
	Indoor Use Only	This treatment device should be used indoors only and should be kept dry.
	Consult Instruc- tions For Use	Read and understand instruction manu-ual/booklet before you start treatment or using the device.
	Not For General Waste (EU States)	This devices is reusable and not contaminated at end of life (complies with WEEE-Directive 2012/19/EU).
	Manufacturer	Hidrex GmbH, Otto-Hahn-Str.12 Heiligenhaus Germany 42579 info@hidrex.de www.hidrex.de
<b>CE 0633</b>	CE Mark, ID# of Notified Body	Conformity with health and safety require-ments set out in European Directive 93/42/EU.
04250571300047  17-3 8005	UDI (Device Identification)	Device Identification: 14-digit unique DI# (Gtin)
	Serial Number (part of UDI)	Serial#: yy-x.xxxx (yy: year of manufacture)

## Lifespan

Legal reasons limit the lifespan of this medical device to 4 years. The manufacturer must recondition the medical device no later than by the end of this term. Each successful reconditioning by the manufacturer extends the lifespan of the medical device by 2 years. If the HIDREX tap water iontophoresis system is reconditioned for the same patient, the treatment trays or carrying case (depending on their condition) do not necessarily have to be replaced.

## Electromagnetic Compatibility

HIDREX devices are developed and manufactured after the stipulated guidelines for electromagnetic compatibility (EMC).



Medical-Electric devices are subject to particular EMC precautions. Please note the following comments and warnings.

### **ELECTROMAGNETIC INTERFERENCE (EMI) WARNING:**

#### **RADIO WAVE SOURCES MAY AFFECT DEVICE CONTROL.**

Radio wave source, such as radio stations, TV stations, amateur radio (HAM) transmitters, two-way radios, and cellular phones, can affect powered devices.

Following the warning listed below should reduce the chance of incidents, which could result in serious injury.

1. Do not turn ON hand-held personal communication devices, such as citizens band (CB) radios and cellular phones, while the device is turned ON;
2. Be aware of nearby transmitters, such as radio or TV stations, and try to avoid coming close to them;
3. If unexpected events occurs, remove treated area from the water and turn the powered device OFF;
4. Be aware that adding accessories or components, or modifying the powered device may make it more susceptible to interference from radio wave sources (Note: There is no easy way to evaluate their effect on the overall immunity to the powered device); and
5. Report all incidents of unexpected events to the powered device manufacturer, and note whether there is a radio wave source nearby.
6. Wearable and mobile HF-Communication facilities, as portable phones or pagers, can influence medical-electric-appliances.

#### **IMPORTANT EMI INFORMATION**

1. 20 volts per meter (V/m) is a generally achievable and useful immunity level against interference from radio wave sources (as of May 1994) (the higher the level; the greater the protection)
2. This device has an immunity level of 20V/m with no accessories connected to the device.

**HIDREX tap water iontophoresis devices should be used in an electromagnetic environment as listed below. The client or user should ensure that it is used in an appropriate environment.**



**Table 1 Electromagnetic Emissions**

<b>Emission tests</b>	<b>Conformity</b>	<b>EMC environment - Guide</b>
RF emission following CISPR 11	Group 1	The test unit generates RF energy only for internal use. Radiation thus is low and it seems unlikely that adjacent medical apparatus is perturbed
RF emission following CISPR 11	Class B	HIDREX tap water iontophoresis devices are suitable for use in all establishments, including domestic establishments and those directly connected to a public low-voltage power supply network that supplies buildings used for domestic purposes.
Mains harmonics following IEC61000-3-2	Class A	
Emission of voltage dips/ flicker following IEC61000-3-3	Compliant	

**Table 2 Electromagnetic Immunity**

<b>Susceptibility</b>	<b>IEC 60601-test level</b>	<b>Actual level</b>
ESD IEC 61000-4-2	+/-6kV cd +/-8kV ad	+/-6kV cd +/-8kV ad
Bursts IEC 61000-4-4	+/-2kV mains +/-1kV I/O	+/-2kV mains +/-1kV I/O
Surges IEC 61000-4-5	+/-1kV dm +/-2kV cm	+/-1kV dm +/-2kV cm
Voltage drops etc IEC 61000-4-11	Reduction to	Reduction to
	5 % for 10 ms / positive amplitude	5 % for 10 ms / positive amplitude
	5 % for 10 ms / negative amplitude	5 % for 10 ms / negative amplitude
	40 % for 100 ms	40 % for 100 ms
	30 % for 500 ms	30 % for 500 ms
	0 % for 5000 ms	0 % for 5000 ms
H- field at 50/ 60 Hz IEC 61000-4-8	3 A/m	3 A/m

**Table 4 Electromagnetic Immunity - Life Support Equipment**

<b>Susceptibility</b>	<b>IEC 60601-test level</b>	<b>Actual level</b>
Conducted RF IEC 61000-4-6	3V <sub>eff</sub> 150 kHz to 80 MHz	3 V
Radiated RF IEC 61000-4-3	3V <sub>eff</sub> 80 MHz to 2.5 GHz	3 V/m

**Table 6 Recommended Separation Distances**

Output power of transmitter W	SAFETY DISTANCE DEPENDING ON FREQUENCY/ M		
	150 kHz to 80 MHz	80 MHz to 800MHz	800 MHz to 2.5 GHz
0.01	0.12 M	0.12 M	0.24 m
0.1	0.37 m	0.37 m	0.74 m
1	1.17 m	1.17 m	2.34 m
10	3.69 m	3.69 m	7.38 m
100	11.67 m	11.67 m	23.34

## Waste Management and Packaging of Electronic Devices



Our packages and the transportation-protection-parts were produced out of non-polluting, salvageable materials. The form parts are from PS (foamed, Polystyrol free of FCKW), foils and bags are from PE (Polyäthylen) and outside-package are of cardboard. Dispose all package-parts in an environmentally acceptable way.

If the device can no longer be used, please dispose of it properly. The national ordinances are to be heeded regarding any other parts.



Appliances that are marked with the marginal symbol cannot be disposed with the house-garbage. You are indebted to dispose of such electro and electronics-garbage separately.

Please inform yourself about the possibility of regular waste disposal within your community. With separate waste disposal, you supply the garbage to the recycling center. Please help prevent incriminating materials from going into the environment (ElektroG).

WEEE-Reg.-Nr.: DE 42510094  
 Manufacturer-# Duales System Interseroh: 134502 (VerpackV)

## Technical Data

### AC Power Adapter (Use genuine part only!)

Input	Input voltage	100-240 V~ / 50-60 Hz
	Max. current	400 mA
Output	Nominal output voltage	12 V=
	Output current	max. 600 mA
	Max. output power	8 VA

## Controller DP450

<b>Display-Tolerance</b>	Treatment Voltage (Dose)	$\pm 2$ V
	Treatment current	$\pm 1$ mA
	Treatment Time	$\pm 1$ %
<b>Dimensions</b>	190 x 49 x 137 mm	(W x H x D)
<b>Mass</b>	0.5 kg	
<b>Power input</b>	Input voltage:	12 V
	Max. input current:	500 mA (fuse)
	Input power:	max. 6 VA
<b>Environmental</b>	Temperature	+10°C to +30°C
<b>Direct current output</b>	Treatment voltage	40 V= max.
	Treatment current	30 mA max.(into a 1 k $\Omega$ load)
	Effective treatment current	30 mA max (5 mA reserved for the device)
	Max. output power	225 mW
<b>Pulsed current output</b>	Treatment voltage	40 V= max.
	Treatment current	30 mA max (into a 1 k $\Omega$ load)
	Effective treatment current	30 mA max (5 mA reserved for the device)
	Pulse repetition frequency	9.9 kHz

## Electrodes

	Material	Dimensions (WxHxD)	Conductive Area
<b>AX-Electrodes</b>	EN AW 5754 (Aluminum)	2.9" x 3.45" x 1.3"	36.75 sq. in.
<b>HF-Electrodes</b>	1.4301-2b (Stainless Steel) or (EN AW 5754 (Aluminum)	4.5" x3.45" x1.3"	122.13 sq. in.
<b>Buffer</b>	None		

## Current Density of Applicators and Electrodes

Applicator/Surface	Conductive Area [sqin]	Max.Density at 30mA [mA/sqin]	Peak Density at 35mA [mA/sqin]
Hand-Feet, Hard Shell Case individual Water Surface	112.13	0.26	0.31
Hand-Feet, Ergonomic Tray individual Water Surface	90.88	0.33	0.38
Hand-Feet, individual Electrode	122.13	0.24	0.28
Hand-Feet, individual Cover Towel	98.8	0.30	0.35
Axillary, Sponge Cushions	36.75	0.81	0.95
Axillary, individual Electrode	8.25	3.63	4.24

## Distribution/Trading



**HIDREX USA, LLC**  
**12400 WEST HIGHWAY 71**  
**SUITE 350-384**  
**AUSTIN, TX 78738**

**TOLL FREE 1-8HIDREXUSA**  
**EMAIL: CUSTOMER.SERVICE@HIDREXUSA.COM**  
**WWW.HIDREXUSA.COM**